

## Installation Instructions

Before you begin installing the UPS, read and understand the following safety information.



**DANGER:** *This unit does NOT have an on/off switch. Whenever it is connected to line or battery power, power is present at the output. Use extreme caution at all times.*



**DANGER:** *NEVER let water from rain, a hose, tap or a sprinkler's output, road splash or other water sources enter the UPS to prevent accidental shorts, shocks or electrocutions.*



**This Uninterruptible Power Supply (UPS) is to be installed by people trained in the safe use of high-energy power supplies and their batteries. Also assumed is knowledge of the local electrical code(s) and their safe application.**



**The UPS MUST be correctly grounded for proper operation.**



**If electrolyte splashes on your skin, immediately wash the affected area with water. If electrolyte gets into your eyes, wash them for at least 10 minutes with clean running water or a special neutralizing eye wash solution. Seek medical attention at once.**

**Neutralize spilled electrolyte with special neutralizing solutions in a "spill kit" or a solution of 1 lb. (0.45 kg) of baking soda (bicarbonate of soda) in 1 gallon (3.9 L) of water.**



**To provide branch circuit protection, the utility line attached to the UPS's input MUST be protected by a circuit breaker certified for this use as per the local electrical code.**

**The breaker's minimum size is calculated by the following formula:**

$$\text{Minimum Breaker Size} = \text{UPS's maximum input current} / 0.8$$

**The UPS's maximum input current is read off of the UPS's nameplate. For example, if the nameplate gives the maximum input current as 20A, the circuit breaker should be rated at least 25A.**



**The input and output lines to and from the UPS MUST have disconnect devices attached.**

**Wall Mounting Checklist:**

- Install the UPS (including batteries) on a surface that can support a minimum of 45 lbs (20.4 kg).
- Input wiring must reach a suitably grounded power outlet.
- Load wiring must reach the output terminal block of the UPS.

**Procedure:**

- 1.** Secure the case to a wall by driving the 4 supplied Phillips-head wood screws through the mounting holes. (See Figure 1.1 below)

Note: The plywood mounting surface must be able to support a minimum of 45 lbs.

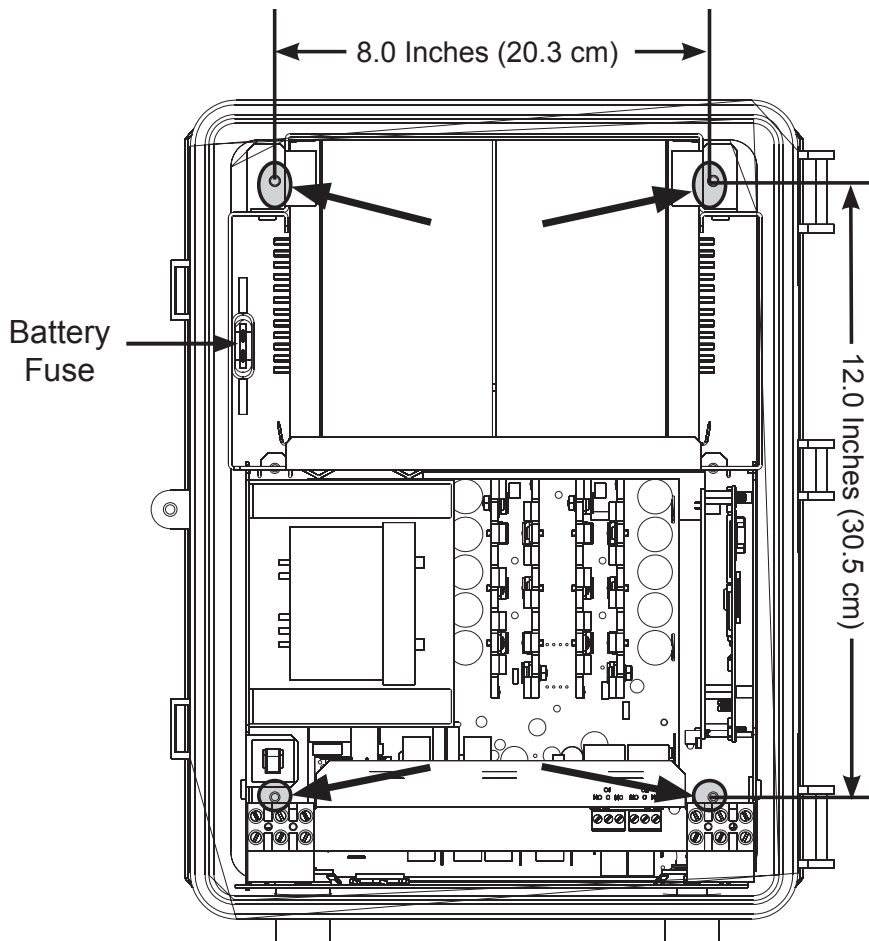

Figure 1.1 – Mounting hole locations (Surveillance version shown)

**2.** Install and wire the batteries as follows:



**DANGER:** Make sure the battery fuse is removed before wiring the batteries.

- a. Install the 4 batteries and wire them up as shown in Figures 2.1 and 2.2 below.

Note: If using only 2 batteries, install them in the Battery #1 and Battery #2 positions and wire them up as shown in Figure 2.2 below, except the wires to Battery #3 and #4 are not used.

- b. Use a DC voltmeter to confirm the battery string's polarity and voltage (24VDC). If they are not correct, perform troubleshooting.

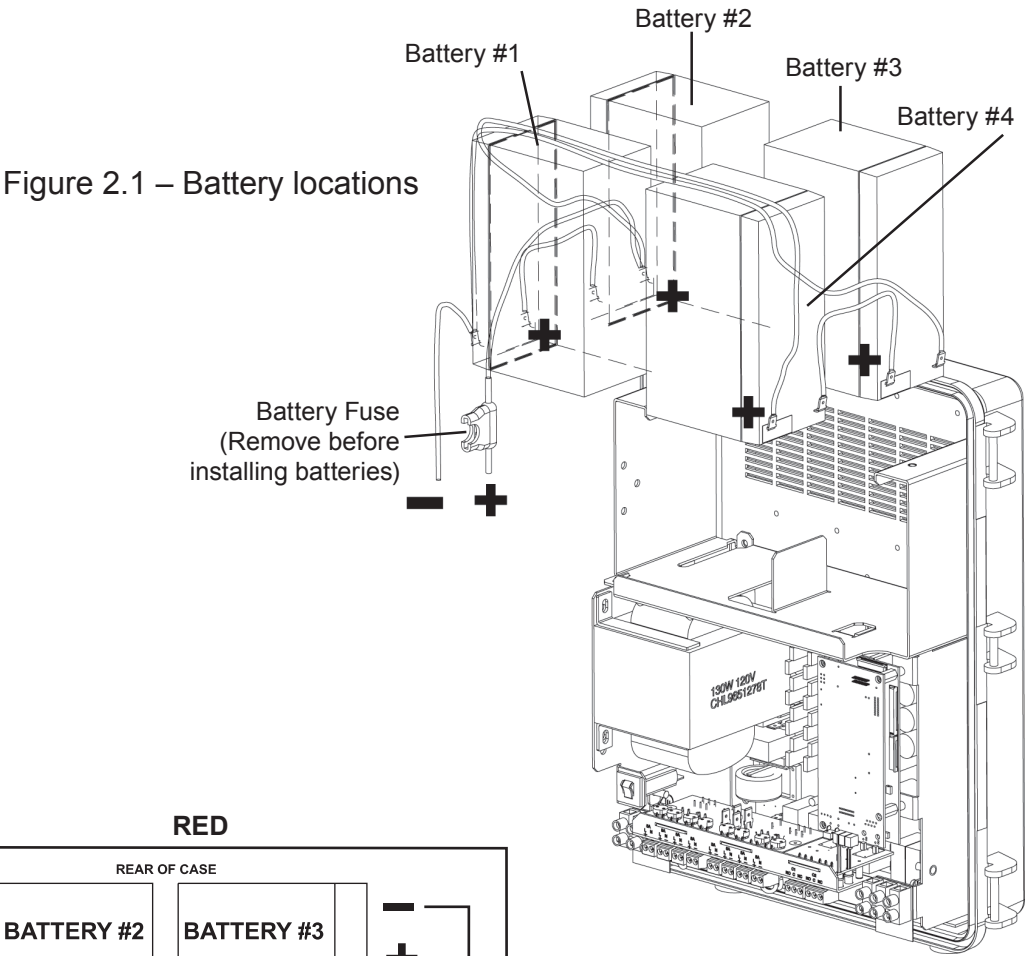

Figure 2.1 – Battery locations

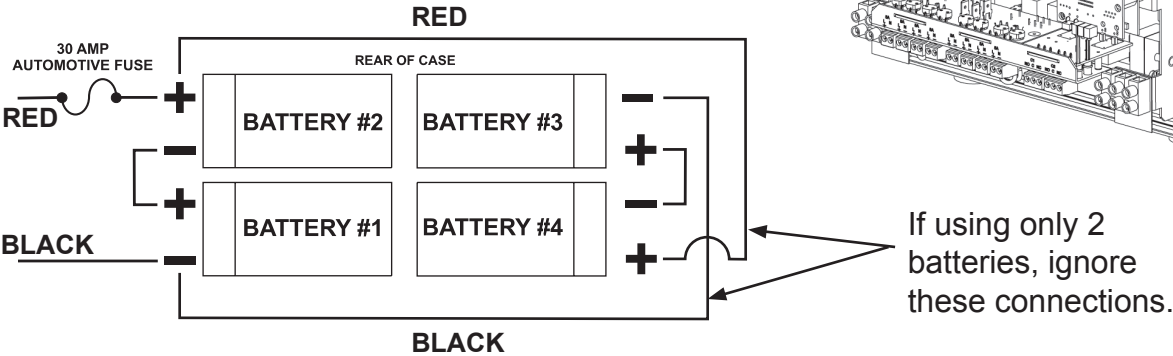
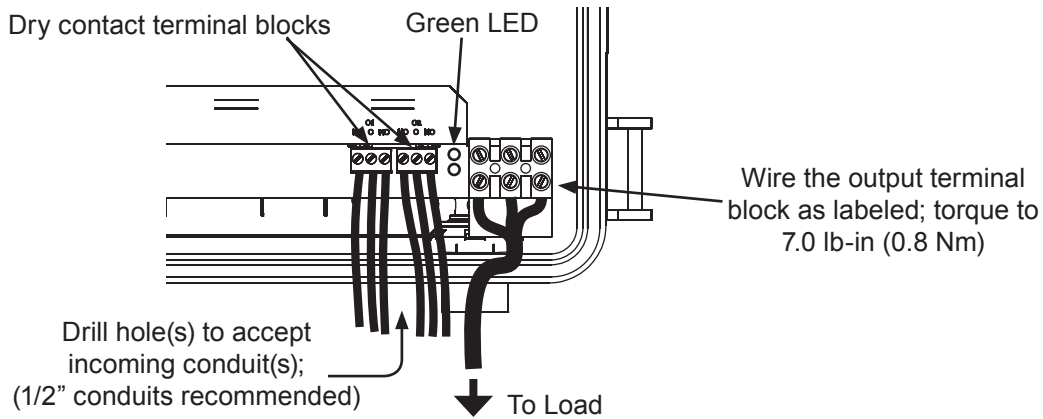

Figure 2.2 – Battery wiring diagram

3. Connect the output terminal block to the load wiring. If you are connecting the dry contacts and the RS-232 or Ethernet connectors to an external monitoring panel, you need to drill a hole for attaching an incoming conduit.

Note: For the cable version, connect the output cable connector.



4. Connect the input line wiring to the input terminal block through the provided knockout.

Note: The cable version has a 6-ft (2m) permanently connected input power cord with a NEMA 5-15P plug for 120V application (for 230V application, connect the line power to the input terminal block through the provided knockout).

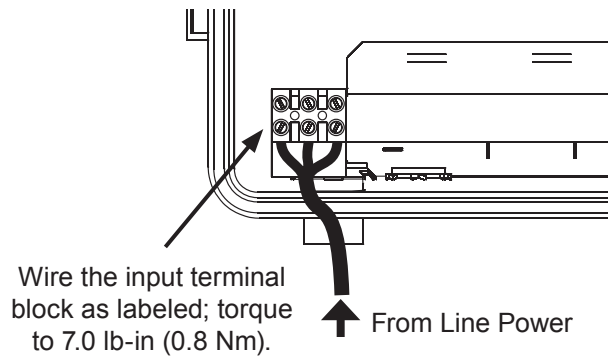

5. Install the battery fuse by snapping it quickly and firmly into the mount. (Figure 1.1)  
Note: You may hear buzzing sound or see sparks; this is normal and will not damage the UPS.
6. Turn on the Line power. Verify that the green LED (on the rail next to the dry contacts) is on if the unit is in line mode, flashing if the unit is in battery mode. If the red LED is on or flashing, the unit has a malfunction.

Note: For the cable version, the green LED is located on the front bottom right corner.

## Installation Finished

To download a copy of the Operator's Manual, visit our web site at [www.alpha.com](http://www.alpha.com).

Contacts: Alpha Technologies Inc., 3767 Alpha Way, Bellingham WA 98226

Alpha Technologies Ltd., 4084 McConnell Court, Burnaby, BC V5A 3N7  
Tel: +1 604 430 1476 Fax: +1 604 430 8908 Toll Free: 1 800 867 8743

[www.alpha.com](http://www.alpha.com)